

**AGENDA
SCHOOL DISTRICT OF MANAWA
BUILDINGS & GROUNDS COMMITTEE MEETING**

Date: April 18, 2018

Time: 5:30 p.m.

**MES Board Room
800 Beech St., Manawa**

Board Committee Members: R. Johnson (C), Scheller, Forbes

In Attendance:

Timer: _____ **Chair:** _____ **Recorder:** _____

1. School Safety Grant – Ideas to consider include: (Information/Action)
 - comprehensive surveillance camera system with an upgraded software management system and integrated card access system option that has a direct link to the Manawa Police Department/Fire Department
 - Panic button capability
 - Security entrances at the Jr./Sr. HS
 - School resource officer program
 - StopIt reporting program
 - Other ?
2. Gym Floors – Will be refinished on June 11 and 12 (Information)
3. Generac Generator – Ordered and anticipated delivery any day now (Information)
4. HS Kitchen Garbage Disposal – On order and will be installed by Woolsey (Information)
5. MES Kitchen Dishwasher – Had not been getting up to temperature for sanitation and has now been repaired (Information)
 - a. Commercial Appliance replaced a faulty valve on the booster heater
 - b. Woolsey Plumbing replaced the calcified elements in the extra kitchen water heater
6. MES Culligan Water Test (Information)
7. Outfield Fence – Purchased and installed at Lindsey Field (Information)
8. Wireless Scoreboard Controller (Information)
 - a. Ordered
 - b. Dave Mackoviak will be doing the electrical installation
9. MES Suspended Light Cables (Information/Action)
 - a. May be included in EE lighting upgrades or may need to be in the B & G budget
 - b. Single broken cable was repaired; connected to beam
 - c. Quote from Dave Mackoviak on adding cables in MES cafeteria and library
10. Track line painting (information/Action)
11. SY1718 Maintenance Budget (Information / Action)
 - a. General Budget
 - b. Snow Removal
12. Site Analysis & Feasibility Study (Information / Action)
13. Update on Energy Efficiency Projects (Information / Action)
 - a. MES Boilers and Water Heaters (low voltage error message on boilers)
 - b. Additional Projects 2018-19: MES Chiller, Windows, Lighting and MES Secured Entrance
14. Buildings & Grounds Committee Planning Guide (Information)
15. Next Meeting Date: _____
16. Next Meeting Items:
 - a.
 - b.

1. Safety Grant – Ideas to Consider Include:
 - Comprehensive Security Camera System
 - Panic button capability
 - Security entrances at the Jr./Sr. HS
 - School resource officer program
 - StopIt reporting program
 - Other ?

Action_____Table _____

2. Gym Floors Action_____Table _____

3. Generac Generator Action_____Table _____

4. HS Kitchen Garbage Disposal Action _____ Table _____

5. MES Kitchen Dishwasher
a. Commercial Appliance replaced a faulty valve
b. Woolsey Plumbing replaced the calcified elements Action _____ Table _____

6. MES Culligan Water Test Action_____Table _____

7. Outfield Fence Action_____Table _____

8. Wireless Scoreboard Controller (Information)
a. Ordered
b. Dave Mackoviak will be doing the electrical installation Action_____Table _____

9. MES Suspended Light Cables
a. May be Included in EE Lighting Upgrades or may need to be in B & G budget
b. Single broken cable was repaired; connected to beam
c. Quote from Dave Mackoviak on adding cables in MES Cafeteria and Library
Action_____Table _____

10. Track line painting Action_____Table _____

11. SY1718 Maintenance Budget

a. General Budget

b. Snow Removal

Action_____Table _____

12. Site Analysis & Feasibility Study

Action_____Table _____

13. Update on Energy Efficiency Projects

a. MES Boilers and Water Heaters

b. Additional Projects 2018-19: MES Chiller, Windows, Lighting and MES Secured Entrance

Action_____Table _____

14. Buildings & Grounds Committee Planning Guide

Action_____Table _____

15. Next Meeting Date _____

Chair: _____

Signature

Date: _____

Time: _____

GENERAC®

iQ2000

iQ SERIES Residential Inverter Portable Generator

iQ2000

1 of 2

Features

- **PowerDial™** integrates start/run/stop functions like the choke and fuel valve into one simple dial.
- **PowerBar™** monitors and displays power used.
- **Run time remaining display** shows how much time is left before the need to re-fuel.
- **Electronic fuel gauge** displays amount of fuel remaining.
- **Turbo, Standard, Economy** modes of operation saves fuel and reduces noise.
- **Status lights** display ready, low oil, overload and overheat alerts.
- **Low-oil level shutdown** safeguards engine from damage.
- **Lightweight compact design** with built-in handle for easy portability.
- **Parallel kit** connects two iQ2000 inverter generators for twice the power (sold separately).
- **Smart paralleling** allows you to connect directly through the 120V outlets, no separate paralleling jacks required.

Model 6866-1 UPC: 696471068665 (EPA/50-State)
Model 7123-0 UPC: 696471072242 (EPA/CSA)



Model 6877-0 UPC: 696471068771



AC Rated Output Running Watts 1600
AC Maximum Output Starting Watts 2000

Control Panel (EPA/50-State shown)

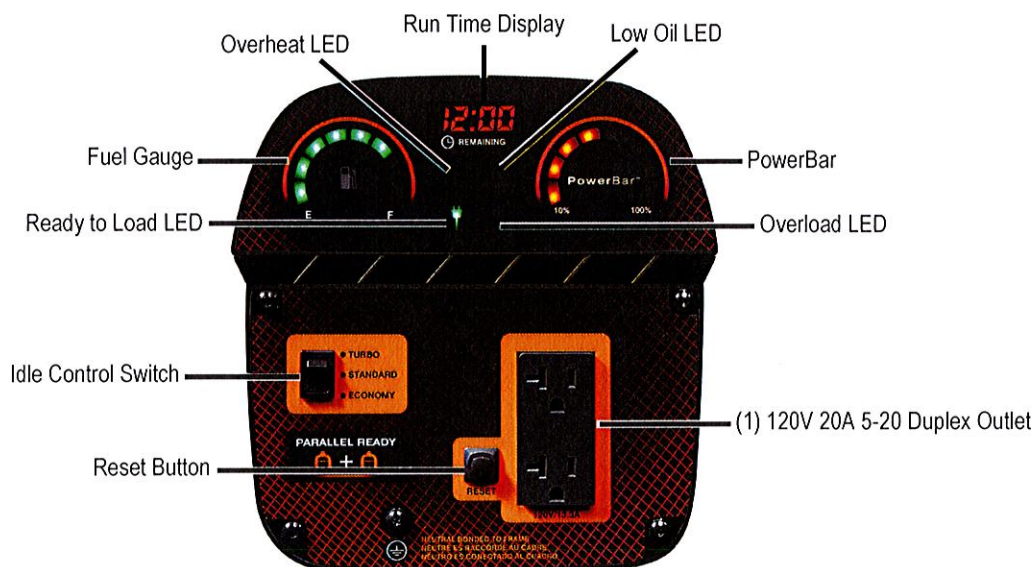

*Built in the USA using domestic and foreign parts

iQ2000

Specifications

Product Series	iQ2000
Model (Configuration)	6866-1 (EPA/50-State) 7123-0 (EPA/CSA)
AC Rated Output Running Watts	1600
AC Maximum Output Starting Watts	2000
Rated AC Voltage	120 VAC
Rated AC Frequency	60 Hz
Rated 120 VAC Amperage	13.3
Engine Displacement	80cc
Engine Type	OHV
Engine RPM	Variable
Recommended Oil	10W-30 / SAE 30
Oil Capacity Qt. (Ltrs)	0.4 (0.38)
Lubrication Method	Splash
Choke Location	PowerDial/On Side of Unit
Fuel Shut Off	PowerDial/On Side of Unit
Starting Method	Recoil Pull Start
Low Oil Shutdown	Low Level
Neutral Bonded to Ground	Yes

Start Switch Type	PowerDial/On Side of Unit
Start Switch Location	On Side of Unit
Fuel Tank Capacity Gal (Ltrs)	1.06 (4.01)
Run Time at 25% of Rated Load (Hours)	7.7
Maintenance Kit	Oil and Funnel
Warranty- Residential	3 Year Limited
Warranty- Commercial	3 Year Limited

Product Series	iQ2000 Parallel Kit
Model	6877-0
Receptacle Type	L5-30R
Rated 120 VAC Amperage	30 Amp
AC Rated Voltage	120 V
Warranty- Residential	90 Day Limited
Warranty- Commercial	90 Day Limited

Dimensions and Weights

iQ2000	
Length in (mm)	20 (507)
Width in (mm)	12.6 (321)
Height in (mm)	16.9 (428)
Carton Length in (mm)	22.6 (574.7)
Carton Width in (mm)	15 (381)
Carton Height in (mm)	19.7 (498)
Unit Weight lbs (kg)	46.5 (21.1)
Shipping Weight lbs (kg)	51 (23.1)

iQ2000 Parallel Kit	
Length in (mm)	8.25 (210)
Width in (mm)	4.63 (118)
Height in (mm)	3.75 (95)
Carton Length in (mm)	8.5 (217)
Carton Width in (mm)	6.2 (157)
Carton Height in (mm)	6.4 (163)
Unit Weight lbs (kg)	2 (0.91)
Shipping Weight lbs (kg)	2.5 (1.15)

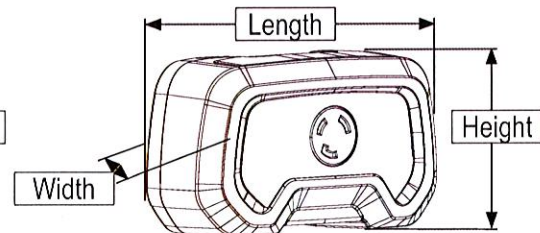
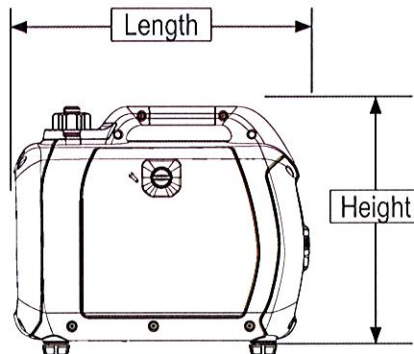
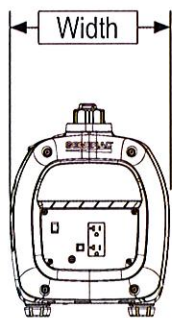

QUOTE

Government Sales

Generac Power Systems
 3815 Oregon Street, Oshkosh, WI USA
 Phone: 920-230-1280
 Fax: 920-230-1201
 Generac.com



Quote No: 20163964

Date: 4/11/18

Melanie J. Oppor, PhD
 District Administrator
 School District of Manawa
 800 Beech Street
 Manawa, WI 54949

QTY	Description	Unit Price	Total Price (USD)
1	Model G0068661, IQ2000 Portable Generator	\$702.72	\$619.88

Comments:

GSA pricing extended as a courtesy. GSA Contract GS-07F-0407X

Sub - Total	\$619.88
Shipping	\$ 63.00
Grand Total	\$682.88

Authorized by: *Thomas Jones*

Pricing reflects TAX EXEMPT: Tax Exempt Form is required for Quote Validity

Generac Power Systems Inc. has active continuous improvement programs in place for our products and processes. We reserve the right to supply any material or use any process or equipment we deem to be equivalent to the part or model number originally quoted or ordered as a result of this quotation. All prices quoted are valid for 30 calendar days from the date of this quotation and are subject to change after that time frame. As the purchaser of these products on a direct basis from Generac Power Systems Inc., you are responsible for the off-loading, troubleshooting, start-up and service, if needed, for these units. Neither Generac Power Systems Inc. nor their domestic / commercial dealers are responsible to perform these functions. All equipment is shipped via common carrier, flatbed semi-trailer or standard ocean container. Any deviation from this practice must be discussed and approved prior to PO receipt and acceptance.

Generac will use our standard commercial practice serial number / data tag. It shall be deemed acceptable for meeting all unique item identifier requirements stated in the Contract.



Anthem Sports, LLC
 2 Extrusion Dr.
 Pawcatuck, CT 06379

Phone	Fax
800-688-6709	860-599-8448
www.anthem-sports.com	

Quote

Date	Quote #
3/16/18	47797

Quote for:
School District of Manawa Sklylar Liebzeit 800 Beech St Manawa, WI 54949

Ship To
School District of Manawa Sklylar Liebzeit 800 Beech St Manawa, WI 54949 920-596-5838

P.O. No.	Terms	Rep
	Net 30	WS

Anthem Part #	Description	Qty	U/M	Price	Total
A15-970	Enduro Fence Package, 314', Dk. Green	1	pkg	1,055.95	1,055.95
A15-972	Enduro Fence Ground Socket Package (32)	1	pkg	173.95	173.95
1	Shipping & Handling			15.06	15.06

Subtotal \$1,244.96

Sales Tax (0.0%) \$0.00

Total \$1,244.96

Quote is valid for 30 days unless otherwise specified.



QUOTATION

This quote is valid for 60 days

FILE NAME: Manawa

DATE: 4-9-18

QUOTED TO: School District of Manawa
Skylar Liebzeit
515 E 4th St.
Manawa, WI 54949
sliebzeit@manawaschools.org
920-596-5838

REF: _____

EQUIPMENT

QTY.	DESCRIPTION	NET
1	MP-80-0213 RF Battery Control & Case <ul style="list-style-type: none"> DAN WEIDNER FOR PROGRAMMING 	\$1,160
1	0000-0032 – Outdoor Transceiver <ul style="list-style-type: none"> DAN WEIDNER FOR PROGRAMMING Field installation required but not included 	\$525
TOTAL		

FREIGHT ESTIMATE	DESTINATION - Manawa, WI	\$30
-------------------------	--------------------------	-------------

QUOTE SUBMITTED BY: Dan Weidner

ESTIMATED DELIVERY: 2 weeks

TERMS: PO required

CANCELLATION: ORDERS FOR CUSTOM-DESIGNED EQUIPMENT MAY BE SUBJECT TO CHARGES TO COVER WORK PERFORMED.

NOTES: PRICE DOES NOT INCLUDE ELECTRICAL OR STRUCTURAL INSTALLATION, CONTROL CABLE OR CONTROL CABLE CONDUIT, FREIGHT OR APPLICABLE TAXES, IF ANY.

TO PLACE ORDER: SCAN/E-MAIL PURCHASE ORDER TO DWEIDNER@FAIR-PLAY.COM

Fair-Play Scoreboards
A Division of Trans-Lux Midwest Corporation
1700 Delaware Ave., Des Moines, Iowa 50317
515-309-6084

PROPOSAL NUMBER 23357 DATED 07-11-17

MASTER ELECTRICAL SERVICES LLC – FOR ALL YOUR ELECTRICAL NEEDS!

PROPOSAL SUBMITTED TO:

WORK TO BE PERFORMED AT:

NAME: School District of Manawa
Attn: Melanie Oppor
ADDRESS: 800 Beech Street
Manawa, WI 54949

LOCATION: Room 305

EMAIL: 596-2525

FAXNO.: 596-5308

We hereby propose to furnish the materials and perform the labor necessary to wire the following;

- Run a 1" conduit from panel in Library to Room 305 and set a junction box to run smaller conduits to each of 6 power poles.
- Pull 12 circuits from panel for 2 circuits to each power pole all with full size grounds.
- Supply the 6 power poles with divider for 120V power and data.

NOTE:

❖ Work to be completed on or before August 18th.

Thank you for the opportunity to serve you!

All material is guaranteed to be as specified, and the above work to be performed in accordance with the drawings and specifications submitted for above work and completed in a substantial workmanlike manner for the sum of:

Four thousand three hundred dollars and 00/100 Dollars **(\$ 4,300.00)**

Any alteration or deviation from above specification involving extra costs will become an extra charge over and above the estimate. All agreements are contingent upon strikes, accidents, or delays beyond our controls. This proposal may be withdrawn by MES if not accepted within 5 days. Acceptance of this proposal provides a Personal Guaranty on behalf of the Acceptor and the above-named Company principals who he/she represents.

Due to the current volatility of the commodity markets (steel, copper, aluminum, brass, plastics, oil, etc.), we are not able to hold firm prices on materials or products for release any further out than factories or suppliers will guarantee. **PRICE IS GOOD AT TIME AND DATE OF ESTIMATE ONLY.** If this proposal is open beyond (30) days, contact us to establish revised pricing.

All materials shall remain the property of Master Electrical Services until paid in full. Customer will be responsible for any and all costs of collection, including, but not limited to, reasonable attorneys fees and filing fees for court actions.

The information and data contained is provided to you as an instrument of service, and intended for use and reference relative only to the specific project they describe. The information may not be copied, modified or released to a third party without the direct written permission of M.E.S. By acceptance of this information, you agree to this confidentiality clause.

Percentage of completion payments respectfully submitted: **MASTER ELECTRICAL SERVICES LLC.**
A 1.5% Service Charge will be added to all balances over 30 days.

Per: 
Dave Mackowiak (sls)

ACCEPTANCE OF PROPOSAL

The above prices, specifications, and conditions are satisfactory and are hereby accepted. You are authorized to do the work as specified above.

Date _____

Signature _____

Master Electrical Services LLC
1913 Mill Street, New London, Wisconsin 54961
(920) 982-6467 FAX (920) 982-6484
General e-mail: general@master-electric.net

Year	Payments	Purchases	Discounts	Encumbered
2017-2018	31,393.99	31,393.99	0.00	0.00

Expand All Collapse All

Monthly Activity				
Month	Payments	Purchase Orders	Discounts	Encumbered
February	9,352.50	9,352.50	0.00	0.00
January	8,667.50	8,667.50	0.00	0.00
December	13,373.99	13,373.99	0.00	0.00

January plowing
December plowing
Sact

BUILDING AND GROUNDS MONTHLY REPORT

Account	Description	2017-18 Original Budget	2017-18 FY Activity	2017-18 FY %	Apr. 2017-18 Monthly Activity
10 E 101 323 253400 000	Upkeep, inspection, etc. of MES equipment	2,000.00	805.38	40.27	0
10 E 101 324 254300 000	Repairs to MES buildings	20,000.00	16,294.96	81.47	1,160.00
10 E 101 324 254300 695	Energy Efficiency projects	875,000.00	586,069.75	66.98	0
10 E 101 331 253000 000	MES gas for heat	30,000.00	24,605.29	82.02	0
10 E 101 336 253000 000	MES electricity	65,000.00	50,972.77	78.42	0
10 E 101 337 253000 000	MES water	1,500.00	2,805.23	187.02	1,253.38
10 E 101 338 253000 000	MES sewer	2,000.00	444.26	22.21	0
10 E 101 3-- -----	*PURCHASED SERVICES	995,500.00	681,997.64	68.51	2,413.38
10 E 101 411 253000 000	Custodial supplies for MES	14,000.00	10,375.20	74.11	20
10 E 101 440 253000 000	Durable supplies for MES sites/grounds, building, or equipment upkeep	500	44.56	8.91	0
10 E 101 4-- -----	*NON-CAPITAL OBJECTS	14,500.00	10,419.76	71.86	20
10 E 101 -- -----	*ELEMENTARY SCHOOL	1,010,000.00	692,417.40	68.62	2,433.38
10 E 400 323 253400 000	Upkeep, inspection, etc. of HS equipment	1,000.00	1,090.03	109	0
10 E 400 324 254300 000	Repairs to HS building	20,000.00	15,506.42	77.53	3,047.07
10 E 400 331 253000 000	HS gas for heat	30,000.00	24,823.56	82.75	0
10 E 400 336 253000 000	HS electricity	90,000.00	68,863.35	76.51	0
10 E 400 337 253000 000	HS water	1,800.00	3,413.91	189.66	1,455.08
10 E 400 338 253000 000	HS sewer	2,500.00	565.8	22.63	0
10 E 400 3-- -----	*PURCHASED SERVICES	145,300.00	114,955.68	79.12	4,502.15
10 E 400 411 253000 000	Custodial supplies for HS	20,000.00	19,669.98	98.35	0
10 E 400 440 253000 000	Durable supplies for HS sites/grounds, building, or equipment upkeep	500	251.47	50.29	0
10 E 400 4-- -----	*NON-CAPITAL OBJECTS	20,500.00	19,921.45	97.18	0
10 E 400 -- -----	*JR./SR. HIGH SCHOOLS	165,800.00	134,877.13	81.35	4,502.15
10 E 800 323 253200 000	Upkeep, inspection, etc. of the sites (grounds)	65,000.00	46,284.24	71.21	755
10 E 800 323 253300 000	Upkeep, inspection, etc. of both buildings	7,000.00	13,276.28	189.66	6,352.00
10 E 800 323 253400 000	Upkeep, inspection, etc. of District equipment	1,500.00	1,213.63	80.91	0
10 E 800 323 253500 000	Upkeep, inspection, etc. to Kubota, truck, or vans	1,500.00	640.83	42.72	0
10 E 800 324 253000 999	E-rate project - technology infrastructure	30,000.00	0	0	0
10 E 800 324 254200 000	Repairs to the sites (grounds)	1,000.00	1,305.50	130.55	0
10 E 800 324 254490 000	Repairs to non-instructional district equipment such as furnishings or equipment (not department specific)	5,000.00	2,305.86	46.12	1,858.83
10 E 800 324 254500 000	Repairs to Kubota, truck, vans	5,000.00	1,782.73	35.65	0
10 E 800 337 253000 000	Old ES water	1,200.00	161.74	13.48	69.18
10 E 800 338 253000 000	Old ES sewer	1,600.00	44.36	2.77	0
10 E 800 342 253000 000	Custodial staff travel to pick up supplies or training	200	69.55	34.78	0
10 E 800 3-- -----	*PURCHASED SERVICES	119,000.00	68,589.39	57.64	9,908.24
10 E 800 411 253200 000	Consumable supplies for sites/grounds operations (upkeep supplies)	10,000.00	1,080.51	10.81	0
10 E 800 411 253400 000	Consumable supplies for equipment operations (upkeep supplies)	100	0	0	0
10 E 800 411 254200 000	Consumable supplies for site/grounds repairs	100	0	0	0
10 E 800 440 253000 000	Durable supplies for sites/grounds or building or equipment upkeep	2,000.00	1,011.49	51.82	0
10 E 800 440 254200 000	Durable supplies for site/ground repairs	500	0	0	0
10 E 800 440 254300 000	Durable supplies for building repairs	2,000.00	230.7	11.54	0
10 E 800 4-- -----	*NON-CAPITAL OBJECTS	14,700.00	2,322.70	15.97	0
10 E 800 517 255000 000	Lindsay Park rental	3,000.00	0	0	0

10 E 800 551 253000 000	New equipment for upkeep of sites/grounds, buildings, non pupil vehicles, security services	10,000.00	7,805.43	95.2	0
10 E 800 5-- ----- --	*CAPITAL OBJECTS	13,000.00	7,805.43	73.23	0
10 E 800 940 253000 000	Permit to operate a boiler - fee	150	0	0	0
10 E 800 9-- ----- --	*OTHER OBJECTS	150	0	0	0
10 E 800 --- ----- ---	*DISTRICT WIDE	146,850.00	78,717.52	54.79	9,908.24

		2017-18 Original Budget	2017-18 FY Activity	2017-18 FY %	Apr. 2017-18 Monthly Activity
10 E 101 --- ----- ---	*ELEMENTARY SCHOOL	\$1,010,000.00	\$692,417.40	68.56	\$2,433.38
10 E 400 --- ----- ---	*JR./SR. HIGH SCHOOLS	\$165,800.00	\$134,877.13	81.35	\$4,502.15
10 E 800 --- ----- ---	*DISTRICT WIDE	\$146,850.00	\$78,717.52	53.60	9,908.24
	TOTALS	\$1,322,650.00	\$906,012.05	68.50	\$16,843.77

QUALITY CONCRETE & EXCAVATING, INC
175 QUALITY DRIVE
BOX 959
MANAWA, WI 54949
PHONE: 920-596-3306

INVOICE DATE
Nov 15, 2017

INVOICE NO
SR 17 0034

PROJECT
SNOW REMOVAL

PO NUMBER
N/A

CUSTOMER
SCHOOL DIST OF MANAWA
800 BEECH ST
MANAWA, WI 54949

DATE	DESCRIPTION	QUANTITY	UNIT	UNIT PRICE	EXTENDED
Nov 7, 2017	THAWROX(TREATED ROAD SALT)	91.29	TON	\$146.50	\$13,373.99

10 E 800 323 253²~~200~~ 000
- COB.
Salt for winter

TOTAL DUE
\$13,373.99

QUALITY CONCRETE & EXCAVATING, INC
175 QUALITY DRIVE
BOX 959
MANAWA, WI 54949
PHONE: 920-596-3306

INVOICE DATE
Dec 31, 2017

INVOICE NO
SR 17 0045

PROJECT
SNOW REMOVAL

PO NUMBER
N/A

CUSTOMER
SCHOOL DIST OF MANAWA
800 BEECH STREET
MANAWA, WI 54949

DATE	DESCRIPTION		QUANTITY	UNIT	UNIT PRICE	EXTENDED
Dec 9, 2017	SNOW REMOVAL	2.5"	1.00	LS	\$960.00	\$960.00
	SANDING TRUCK		1.50	HRS	\$135.00	\$202.50
	WALKWAY LABOR		7.00	HRS	\$70.00	\$490.00
Dec 13, 2017	SNOW REMOVAL	3.5"	1.00	LS	\$960.00	\$960.00
	SANDING TRUCK		2.50	HRS	\$135.00	\$337.50
	WALKWAY LABOR		7.00	HRS	\$70.00	\$490.00
Dec 17, 2017	SNOW REMOVAL	2.5"	1.00	LS	\$960.00	\$960.00
	SANDING TRUCK		2.00	HRS	\$135.00	\$270.00
	WALKWAY LABOR		4.00	HRS	\$70.00	\$280.00
Dec 22, 2017	SNOW REMOVAL	3.5"	1.00	LS	\$960.00	\$960.00
	SANDING TRUCK		2.50	HRS	\$135.00	\$337.50
	WALKWAY LABOR		6.00	HRS	\$70.00	\$420.00
Dec 29, 2017	SNOW REMOVAL	1.5"	1.00	LS	\$960.00	\$960.00
	SANDING TRUCK		2.00	HRS	\$135.00	\$270.00
	WALKWAY LABOR		11.00	HRS	\$70.00	\$770.00

TOTAL DUE
\$8,667.50

QUALITY CONCRETE & EXCAVATING, INC
 175 QUALITY DRIVE
 BOX 959
 MANAWA, WI 54949
 PHONE: 920-596-3306

PAGE 1 OF 1
INVOICE DATE
 Jan 31, 2018
INVOICE NO
 SR 18 0001
PO NUMBER
 N/A

PROJECT
 SNOW REMOVAL

CUSTOMER
 SCHOOL DIST OF MANAWA
 800 BEECH ST
 MANAWA, WI 54949

DATE	DESCRIPTION	QUANTITY	UNIT	UNIT PRICE	EXTENDED
Jan 7, 2018	SNOW REMOVAL 1"	1.00	LS	\$960.00	\$960.00
	SANDING TRUCK	2.00	HRS	\$135.00	\$270.00
	WALKWAY LABOR	6.00	HRS	\$70.00	\$420.00
Jan 11, 2018	SANDING TRUCK	1.00	HRS	\$135.00	\$135.00
Jan 12, 2018	SNOW REMOVAL 2"	1.00	LS	\$960.00	\$960.00
	SANDING TRUCK	2.50	HRS	\$135.00	\$337.50
	WALKWAY LABOR	8.00	HRS	\$70.00	\$560.00
Jan 15, 2018	SNOW REMOVAL 2"	1.00	LS	\$960.00	\$960.00
	SANDING TRUCK	2.50	HRS	\$135.00	\$337.50
	WALKWAY LABOR	8.00	HRS	\$70.00	\$560.00
Jan 16, 2018	SNOW REMOVAL 2.5"	1.00	LS	\$960.00	\$960.00
	SANDING TRUCK	2.50	HRS	\$135.00	\$337.50
	WALKWAY LABOR	8.00	HRS	\$70.00	\$560.00
Jan 23, 2018	SNOW REMOVAL 2"	1.00	LS	\$960.00	\$960.00
	SANDING TRUCK	2.50	HRS	\$135.00	\$337.50
	WALKWAY LABOR	9.00	HRS	\$70.00	\$630.00
Jan 27, 2018	SANDING TRUCK	0.50	HRS	\$135.00	\$67.50

10 8 800 323 253200 000

1/7/18	SNOW REMOVAL	1.00	LS	\$960.00	\$960.00
1/11/18	SANDING TRUCK	1.00	HRS	\$135.00	\$135.00
1/12/18	SNOW REMOVAL	1.00	LS	\$960.00	\$960.00
1/12/18	SANDING TRUCK	2.50	HRS	\$135.00	\$337.50
1/12/18	WALKWAY LABOR	8.00	HRS	\$70.00	\$560.00
1/15/18	SNOW REMOVAL	1.00	LS	\$960.00	\$960.00
1/15/18	SANDING TRUCK	2.50	HRS	\$135.00	\$337.50
1/15/18	WALKWAY LABOR	8.00	HRS	\$70.00	\$560.00
1/16/18	SNOW REMOVAL	1.00	LS	\$960.00	\$960.00
1/16/18	SANDING TRUCK	2.50	HRS	\$135.00	\$337.50
1/16/18	WALKWAY LABOR	8.00	HRS	\$70.00	\$560.00
1/23/18	SNOW REMOVAL	1.00	LS	\$960.00	\$960.00
1/23/18	SANDING TRUCK	2.50	HRS	\$135.00	\$337.50
1/23/18	WALKWAY LABOR	9.00	HRS	\$70.00	\$630.00
1/27/18	SANDING TRUCK	0.50	HRS	\$135.00	\$67.50

TOTAL DUE
\$9,352.50

QUALITY CONCRETE & EXCAVATING, INC
175 QUALITY DRIVE
BOX 959
MANAWA, WI 54949
PHONE: 920-596-3306

INVOICE DATE
 Feb 28, 2018

INVOICE NO
 SR 18 0013

PROJECT
 SNOW REMOVAL

PO NUMBER
 N/A

CUSTOMER
 SCHOOL DIST OF MANAWA
 800 BEECH ST
 MANAWA, WI 54949

DATE	DESCRIPTION	QUANTITY	UNIT	UNIT PRICE	EXTENDED
Feb 4, 2018	SNOW REMOVAL 6"	1.00	LS	\$960.00	\$960.00
	SANDING TRUCK	2.50	HRS	\$135.00	\$337.50
	WALKWAY LABOR	12.00	HRS	\$70.00	\$840.00
Feb 9, 2018	310 JD 4 X 4 TRACTOR/BACKHOE	1.50	HRS	\$150.00	\$225.00
Feb 20, 2018	SANDING TRUCK	5.00	HRS	\$135.00	\$675.00
Feb 23, 2018	SANDING TRUCK	5.00	HRS	\$135.00	\$675.00

TOTAL DUE
 \$3,712.50